

Series II

FULL HYDRAULIC EXCAVATOR

# TB1140

Machine Weight : 14775kg



TAKEUCHI

# TAKEUCHI

## OPERATING RANGE : mm

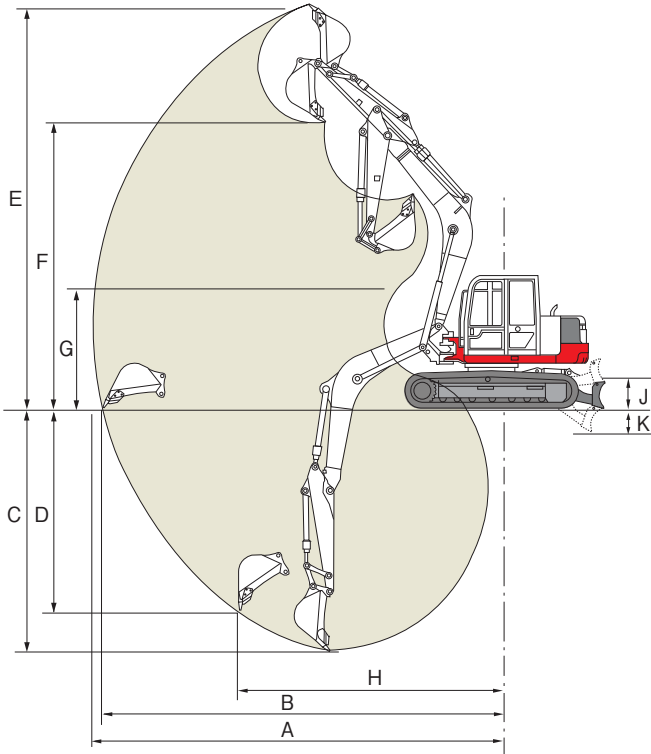

## DIMENSION : mm

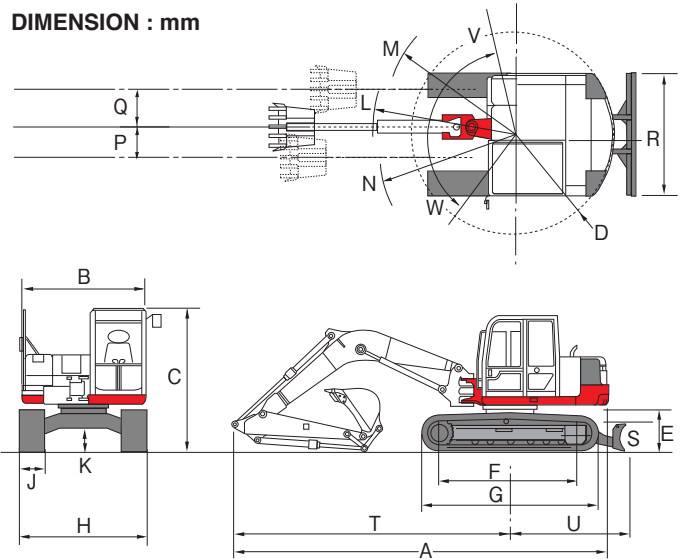

### Operating Range (Rubber Crawlers)

	Standard	Middle	Long
A	8280	8520	8755
B	8080/8090*	8325	8570
C	4985/5020*	5235/5270*	5485/5520*
D	4135/4170*	4375/4410*	4620/4650*
E	8315/8280*	8495/8460*	8670/8640*
F	5860/5830*	6045/6010*	6220/6190*
G	2340/2310*	2105/2070*	1855/1825*
H	5240	5305	5365
J	540/505*	←	←
K	510/545*	←	←

Units:mm \* : With steel crawlers

### Machine Dimensions (Rubber Crawlers)

	Standard	Middle	Long		Standard	Middle	Long
A	7725	7780	7815	L	2885	2965	3015
B	2460	←	←	M	2285	2360	2405
C	2815/2805*	←	←	P	625	←	←
D	2000	←	←	Q	910	←	←
E	930/895*	←	←	R	2490	←	←
F	2900/2890*	←	←	S	550	←	←
G	3615/3600*	←	←	T	5725	5780	5815
H	2490	←	←	U	2410	←	←
J	500	←	←	V	77°	←	←
K	475/440*	←	←	W	53°	←	←

Units:mm \* : With steel crawlers

### SPECIFICATIONS TB1140

<b>WEIGHT</b>			
Machine Weight	kg		14775
<b>BUCKET</b>			
Capacity (Heaped)	m <sup>3</sup>		0.45
Bucket Width	mm		850
<b>ENGINE</b>			
Engine Model	ISUZU AM-4JJ1XZSB-01		
Engine Compliance	Stage III B / EPA Interim Tier 4		
Cylinders and Type	4 / 4 Cycle		
Rated Output : kW/min <sup>-1</sup> (ISO 14396)	77 / 2000		
Rated Output : kW/min <sup>-1</sup> (ISO 9249/SAEJ1349)	71.8 / 2000		
Maximum Torque	N·m		385
Displacement	mL		2999
Engine Coolant	L		18.5
Fuel Tank	L		233
Battery (IEC 60095-1)	12V / 104x2 A·h		
<b>PERFORMANCE</b>			
Travel Speed (1st/2nd)	km/h		3 / 5.3
Maximum Tractive Force	kN		72.4
Upper Slew Speed	min <sup>-1</sup>		13.4
Gradeability	degrees		35.0
Maximum Digging Force Bucket	kN		98.7
Maximum Digging Force Arm	kN		64.9
Ground Pressure : kPa			45.3
<b>HYDRAULIC SYSTEM</b>			
Pump Type	Variable x 2 + Gear x 2		
Set Pressure	MPa		34.3 x 2 + 23.6 + 3.9
Discharge	L/min		112 x 2 + 54.8 x 1 + 20 x 1
Slew Motor	Piston Motor		
Travel Motor	2-Speed Piston Motor		
Hydraulic Oil Capacity	L		95
<b>SAFETY</b>			
Safety	ROPS,OPG		
<b>OPTION &amp; EQUIPMENTS</b>			
SP1 : Flow Rate / Pressure (L / MPa) <High flow>			112 / 24.5 <224/24.5>
SP2 : Flow Rate / Pressure (L / MPa)			54.8 / 23.6
SP3 : Flow Rate / Pressure (L / MPa)			A:20/3.9 B:54.3/23.6
SP4 : Flow Rate / Pressure (L / MPa)			54.8 / 23.6

# TAKEUCHI

WORLD CREATOR OF COMPACT EXCAVATOR  
**TAKEUCHI MFG.CO.,LTD.**

205, Uwadaira, Sakaki-machi, Hanishina-gun.  
 Nagano 389-0605, Japan  
 Phone (81)268-81-1112  
 Telefax (81)268-81-1121  
 URL <http://www.takeuchi-mfg.co.jp>  
 E-mail: [marketing@takeuchi-mfg.com](mailto:marketing@takeuchi-mfg.com)

**Semco**<sup>TM</sup>  
 Equipment Sales

**1800 685 525**

[www.semco-group.com.au](http://www.semco-group.com.au)

Sydney, Queanbeyan, Newcastle, Goulburn,  
 Brisbane and Melbourne